

FLOWer
Transcatheter Antiembolic Filter
AorticLab S.r.l.

Instructions for Use

April 28th, 2026

FLOWer Instructions for Use

FIGURES

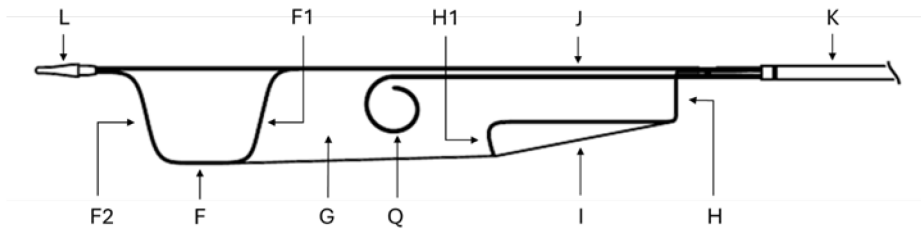

Figure 4 - FLOWer device distal structure

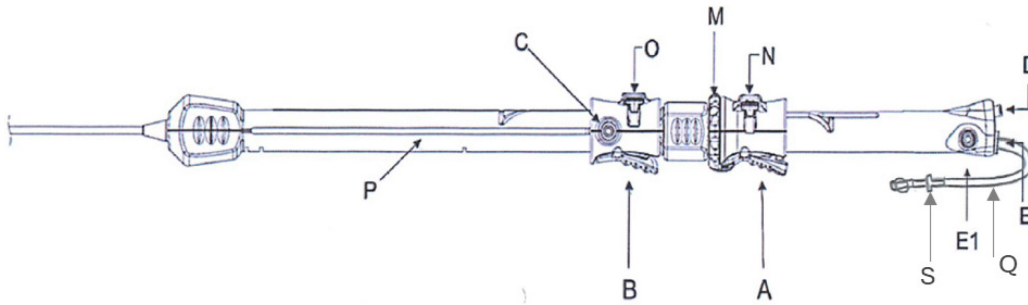

Figure 3 - FLOWer device handle

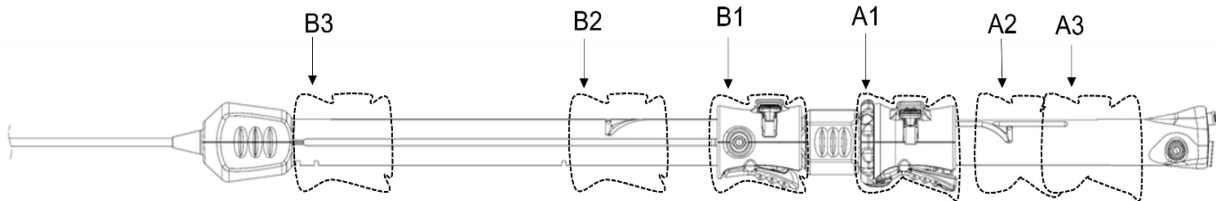

Figure 2 - FLOWer device handle and slider positions

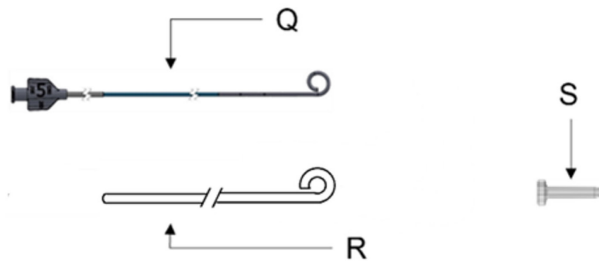

Figure 1 - FLOWer accessories

A	Distal structure slider with its fin	E	Pigtail port	K	Outer catheter
A1	Distal structure slider open position	E1	Pigtail-dedicated lumen flush port	L	Tip
A2	Distal structure slider preclosing position	F	Distal structure	M	Safety ring of distal structure slider
A3	Distal structure slider closed position	F1	Proximal ring of distal structure	N	Distal structure safety lever
B	Outer catheter slider with its fin	F2	Distal ring of distal structure	O	Outer catheter safety lever
B1	Outer catheter slider open position	G	Filter	P	Handle
B2	Outer catheter slider preclosing position	H	Proximal structure port	Q	Pigtail
B3	Outer catheter slider closed position	H1	Proximal structure distal ring	Q1	Pigtail soft tip
C	Outer catheter flush port	I	Funnel	R	Stylet
D	Guidewire port	J	Inner catheter	S	Pigtail straightener

FLOWer Instructions for Use

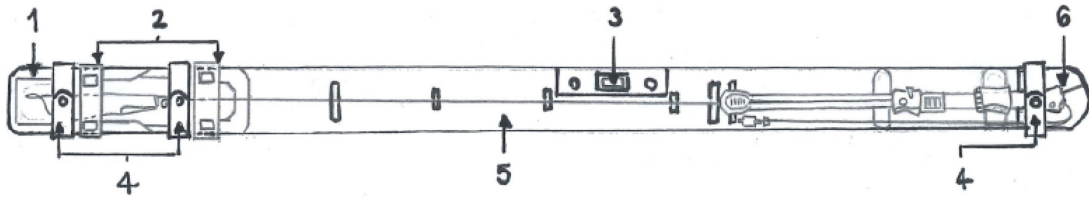

Figure 5 - FLOWer blister

1	Tray	4	Strips
2	Transport clips	5	Card
3	Priming clip	6	Case back

FLOWer Instructions for Use

CONTENTS

1. PRODUCT DESCRIPTION	5
1.1. Packaging content	6
2. INTENDED USER	6
3. INTENDED PATIENT POPULATION.....	6
4. INTENDED PURPOSE OF THE DEVICE	6
5. MEDICAL CONDITIONS TO BE TREATED.....	6
6. CLINICAL BENEFIT & PERFORMANCE	6
7. INDICATIONS FOR USE	7
8. CONTRAINDICATIONS FOR USE AND/OR LIMITATIONS.....	7
9. DEVICE SIZING	8
10. WARNINGS	9
11. PRECAUTIONS	9
12. ADVERSE EVENTS	9
13. USER TRAINING	10
14. INSTRUCTION FOR USE	10
14.1 Preliminary procedure assessment.....	10
14.2 Device compatibility.....	10
14.3 Required Accessories	10
14.4 Packaging handling	10
14.5 Device Priming	11
14.6 Procedural use – Deployment.....	11
14.7 Procedural use – Interaction with other devices.....	13
14.8 Procedural use – Retrieval	13
15. COMPLAINTS AND MALFUNCTIONING	14
16. DEVICE DISPOSAL	14
17. WARRANTY.....	14
18. MANUFACTURED BY	14
19. FLOWer HANDLE SYMBOLS.....	15
20. FLOWer LABELS SYMBOLS.....	16
21. TROUBLESHOOTING GUIDE	18

AORTICLAB FLOWer – Transcatheter Antiembolic Filter

WARNINGS:

Carefully read all instructions prior to use. Observe all contraindications, warnings, cautions, and precautions in these instructions.

Contents supplied STERILE using an Ethylene Oxide (ETOX) process. Do not use if sterile barrier package is damaged.

For single use only.

Do not reuse, reprocess, or re-sterilize as these may result in patient injury, illness or death and may compromise the structural integrity of the device and/or lead to device failure or contamination of the device and/or cause patient infection or cross-infection, including, but not limited to, the transmission of infectious disease(s) from one patient to another.

The reinsertion of the device can be allowed only in the same patient. This procedure can be done only if the device is kept sterile.

1. PRODUCT DESCRIPTION

FLOWer is a sterile, invasive, not implantable, not active, for transient use medical device, which operates inside the central circulatory system, therefore it is classified class III according to Reg. EU 2017/745 (MDR), Annex VIII, Rule 6, third indent.

The FLOWer device is an embolic protection filter inserted through a femoral artery access in the ascending aorta, deployed upstream the Innominate artery and covering the aortic arch, to reduce the risk of embolization into cerebral and systemic circulation (e.g., cerebral damages, acute kidney injuries, etc.) caused by blood clots and/or debris released in the blood flow. A release system is used to allow the Users (ref. to 2) to easily deploy the device via femoral access.

Once anticoagulants have been administered, FLOWer is deployed before positioning the working catheters used for the treatment of cardiovascular disease. At the completion of the treatment, after retrieving the other devices, the filter is safely closed, retrieved in its outer catheter with all the captured debris inside the filter net and removed from the patient.

Deployment and retrieve are performed acting on the two sliders. The sliders can only be moved along a single direction. The deployment phase is performed by moving the outer catheter slider backward to deploy the device and uncover the filter mesh; the distal structure slider is then moved forward to expand the distal structure. The retrieval phase is made by moving the distal structure slider backward to collapse the distal structure and then the outer catheter slider is moved forward to recapture the filter, closing it inside its lumen.

The device is equipped with a 5 Fr pigtail that can be used for the visualisation of the anatomical structures during the procedure. The proximal structure port, the inner catheter, the distal structure of the filter and the tip are radiopaque to allow their visibility under fluoroscopy during the positioning and deployment of the device.

In Table 1 and Table 2 the information and specifications of the AorticLab FLOWer device are summarized.

Table 1 - Available FLOWer sizes

MODEL	Product Code (REF)	Device nominal size (mm)
FLOWer 28	PF-TAF-028	28
FLOWer 32	PF-TAF-032	32
FLOWer 36	PF-TAF-036	36

Table 2 - FLOWer specifications

Introducer compatibility	12 Fr
Working length	110 cm
Filter length	21 cm
Pigtail Size	5 Fr
Pigtail length	200 cm
Pigtail Guidewire compatibility	0.035" diameter floppy tip guidewire, non-hydrophilic coated 260 cm minimum length
Guidewire compatibility	0.035" diameter floppy tip super stiff guidewire, non-hydrophilic coated 260 cm minimum length

FLOWer Instructions for Use

1.1. Packaging content

The FLOWer device is provided sterile to the user and packaged in a carton.

A carton contains:

- one (1) Sterile Barrier Systems (SBS or pouch) with:
 - one (1) AorticLab FLOWer device;
 - one (1) pigtail (Q);
 - one (1) pigtail straightener (S);
 - one (1) stylet (R).

WARNINGS

- Visually inspect the SBS for breaches of packaging integrity prior to use: do not use the device if SBS is open or damaged;
- Never use a damaged product;
- Do not use the device if lot number, expiration date and size are not specified;
- Do not use if labelling is incomplete or illegible;
- Check the expiration date before use. Never use an expired device;
- Do not insert any other pigtails in the dedicated port (E) except the one (Q) provided with the device;
- Store in dry place at room temperature and keep away from sun light.

WARNING

- The permanence of FLOWer device in the patient's body for more than one (1) hour may occur without increasing the thromboembolic risk for the patient, provided that the patient is maintained under anticoagulants as per standard procedure.

2. INTENDED USER

The AorticLab FLOWer device is intended for Healthcare Professionals (Interventional Cardiologists, Interventional Radiologists, Electrophysiologists and Cardiac Surgeons) trained and skilled in transcatheter cardiovascular procedures.

3. INTENDED PATIENT POPULATION

FLOWer is indicated to use in adult patients (≥ 18 years) with cardiovascular disease and who meet the clinically approved indications for cardiovascular transcatheter interventional procedures, which carry a risk of emboli traversing in the ascending aorta.

4. INTENDED PURPOSE OF THE DEVICE

FLOWer is an embolic protection device intended to capture and remove embolic material that may enter the cerebral and systemic vascular circulation during cardiovascular transcatheter interventional procedures which carry a risk of emboli traversing the ascending aorta.

5. MEDICAL CONDITIONS TO BE TREATED

The AorticLab FLOWer device is aimed at being used in subjects with cardiovascular diseases who meet the clinically approved indications for transcatheter interventional procedures which may carry the risk of releasing emboli into the aorta. It is used in combination with transcatheter devices for the cardiovascular treatment. It is designed to make all cardiovascular transcatheter interventions safer, in term of cerebral strokes occurrence, protecting the cerebral and systemic circulation by capturing and removing debris that may be released during the procedure.

6. CLINICAL BENEFIT & PERFORMANCE

The intended clinical benefit from the use of the FLOWer device is the protection of the patients' brain and systemic organs against accidental emboli released during a cardiovascular transcatheter interventional procedure, reducing the risk of occurrence of cerebrovascular accidents and peripheral vascular complications.

FLOWer Instructions for Use

The performance characteristics of the device is the protection of the brain and systemic organs from embolic migration through the epiaortic vessels and the systemic circulation, due to its stability within the aorta, contributing to the preservation of the patient's neurological status.

7. INDICATIONS FOR USE

The following indications must be accomplished:

1. Subjects of age ≥ 18 years;
2. Subject is scheduled to undergo a cardiovascular transcatheter interventional procedure performed and is qualified based on pre-operative assessment via CT-scan examination (preferred), trans-thoracic echocardiography (TTE) or angiography;
3. Subject anatomy with Ilio-femoral artery segment compatible with a 12 Fr device catheter size.

The above listed indications for use have been revised after the Nautilus clinical trial and reflect the indications for the device placed on the market. The explanation of changes among the indications for use listed in Nautilus study CIP and the current ones are reported in the SSCP document.

8. CONTRAINDICATIONS FOR USE AND/OR LIMITATIONS

Based on pre-procedural planning, considering the FLOWer device's intended use, and its mode of operation, for which safety and performance have been demonstrated, the following procedural, clinical and anatomical exclusion criteria are established:

Procedural exclusion criteria

1. A procedure requiring a different anatomical deployment target of FLOWer (10 mm upstream the brachiocephalic trunk)
2. A procedure in which, during deployment, the FLOWer device is unable to achieve the intended apposition to the aortic wall due to the presence of an external working catheter (all working catheters must pass through the FLOWer device).
3. A procedure requiring the FLOWer device to capture, during use, biological or non-biological (e.g., prosthetic origin) embolic material that compromises the structural integrity of the filter material or prevents proper closure and retrieval of the filter.

Clinical exclusion criteria (preoperative screening)

1. Subjects with hypercoagulable state that cannot be corrected by additional periprocedural heparin;
2. Subjects with known diagnosis of acute myocardial infarction (AMI) within 30 days preceding the index procedure;
3. Renal insufficiency (creatinine > 3.0 mg/dl or GFR < 30) and/or renal replacement therapy at the time of screening;
4. Subjects with a history of bleeding diathesis or coagulopathy or patients in whom anti-platelet and/or anticoagulant therapy is contraindicated, patients who will refuse transfusion, or patients with an active peptic ulcer or history of upper gastrointestinal (GI) bleeding within the prior 3 months;
5. Subjects with known hypersensitivity or contraindication to aspirin, heparin/bivalirudin, clopidogrel/ticlopidine, nitinol, stainless steel alloy, nickel and/or contrast sensitivity that cannot be adequately pre-medicated;
6. Subjects with active endocarditis or other systemic infection;
7. Subjects undergoing therapeutic thrombolysis;
8. Subject is pregnant or lactating.

Anatomical exclusion criteria (preoperative screening)

1. Subjects with a diameter of the ascending aorta minor than 25 or greater than 39 mm (measured 10 mm upstream the first vessel of the brachiocephalic trunk as in Figure 6);
2. Subjects undergoing cardiovascular transcatheter interventional procedures via the trans-axillary, trans-subclavian and trans-aortic route using radial or brachial artery accesses;
3. Subjects with severe peripheral arterial, abdominal aortic, or thoracic aortic disease that precludes delivery sheath vascular access;
4. Subjects in whom the aortic arch is heavily calcified, severely atheromatous or severely tortuous.

These criteria can be assessed by CT scan, echocardiography, angiography or any other suitable method allowing the measurement of the ascending aorta's diameter.

FLOWer Instructions for Use

The above listed contraindications have been revised after the clinical trial and reflect the contraindications for the device placed on the market. The explanation of changes among the contraindications listed in Nautilus study CIP and the current ones are reported in the SSCP document.

9. DEVICE SIZING

Different sizes of the FLOWer device are indicated according to aortic diameters. The aortic diameter 10 mm upstream the insurgence of innominate artery (D1 in Figure 6), corresponding to the device landing zone, allows to choose the device according to Table 3.

Table 3 - Indication for device sizing

FLOWer Model	D1 dimensional ranges
FLOWer 28	25 mm ≤ D1 ≤ 29 mm
FLOWer 32	29 mm < D1 ≤ 34 mm
FLOWer 36	34 mm < D1 ≤ 39 mm

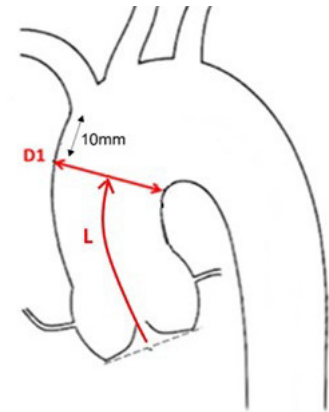
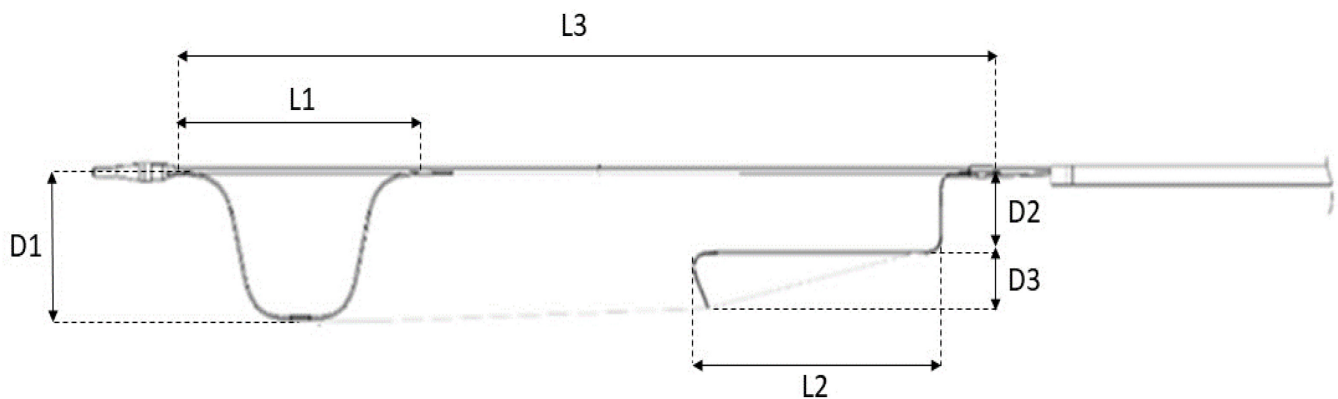

Figure 6 - Assessment of measures of interest: D1 and L



	Size28			Size 32			Size 36		
	<i>min</i>	<i>nominal</i>	<i>max</i>	<i>min</i>	<i>nominal</i>	<i>max</i>	<i>min</i>	<i>nominal</i>	<i>max</i>
D1	25	28	29	29	32	34	34	36	39
L1	\	66	59	\	76	69	\	86	79
D2	18			18			18		
D3	12			12			12		
L2	60			60			60		
L3	212			212			212		

Figure 7 - FLOWer device dimensions (mm) for every size. It is possible to foresee in the CT scan where every FLOWer structure will land in the aorta. The measurements shall be done on the extrados of the aorta

FLOWer Instructions for Use

WARNINGS:

- The distance from the aortic root plane to the FLOWer landing zone, indicated by L in Figure 6, can be critical in patients with very short ascending aorta because of risk of interaction with devices to be temporarily placed or implanted in the aortic root. It must be at least 30 mm longer than the aortic tract occupied by the working device.
- Control the anatomy of the femoral artery before the procedure in order to evaluate the tortuosity of the vessels and the presence of narrowing created by atherosclerotic plaques.
- The target positioning of the FLOWer device is with the bottom of radiopaque tip at least 10mm upstream the first branch (D1). If the anatomy of the aortic arch shows a lumen shrinking due to its morphology and/or the presence of annular calcifications that could interfere with the distal structure opening, consider the possibility to position the device slightly upstream or downstream the target point, still ensuring the protection of all branches and avoiding the interference with device in aortic root. If repositioning is necessary, verify that the size chosen is still compatible with landing zone diameter. Calcifications and lumen shrinking can be detected in pre-operative analysis, by looking at the view section of the aorta.
- Pay attention in patients with very long ascending aorta and aortic arch. If, after the FLOWer positioning and deployment, the proximal structure is not placed in descending aorta, interference with working catheters navigation may occur. If this is the case, reposition the device maintaining the protection of the epiaortic vessels. If this is not possible, retrieve the FLOWer device.

10. WARNINGS

- Refer to the instructions for use supplied with any interventional devices to be used in conjunction with the FLOWer device;
- Do not modify the device;
- Do not use the device improperly;
- Do not use the device in patients that do not fulfill the indication and contraindication for use;
- The appropriate antiplatelet/anticoagulation treatment should be administered pre- and post-procedure in accordance with standard medical practice;
- Do not use the device in radial or brachial accesses;
- During use, verify that the device is not compromising the normal blood flow;
- Do not apply excessive pushing force during the device navigation into the aorta. If excessive resistance is observed, stop the advancement, retract and re-advance the device. This may lead to distal embolization of debris and vessel and/or device damage;
- Do not apply excessive force on the guidewire if excessive friction is perceived. This could damage the device;
- Do not apply excessive pushing force on the pigtail. This may lead to aortic valve damage.
- Do not apply excessive force or execute abrupt movement on the sliders during FLOWer deployment and retrieve of the distal structures.

11. PRECAUTIONS

- Improper bending may damage the device catheter and pigtail;
- Retrieve the device in case of patient suffering;
- Advance the device carefully in case of patients with fragile vessels (e.g., aneurism).

12. ADVERSE EVENTS

Possible adverse events during cardiovascular transcatheter interventional procedures in association with the AorticLab FLOWer device include, but are not limited to, the following: aorta's plaque dissection, aorta's perforation with major bleeding, cardiac arrhythmias, cardiac tamponade or pericardial effusion, myocardial infarction, native aortic leaflet perforation or tear, cerebral ischemia major or minor, acute kidney injury, peripheral embolization, dissection or perforation of femoral artery access, access site major or minor bleeding, access site major vascular complications, structural deterioration, endocarditis, infection other than endocarditis, hemolysis, allergic or toxic reaction, death.

Serious Adverse Events and Device Deficiencies must be communicated to the Competent Authority of the Country where the procedure takes place and to the Manufacturer.

13. USER TRAINING

The device shall only be used by Healthcare Professionals (ref. to 2) who have received appropriate training with the FLOWER procedure. The Manufacturer has defined a specific training plan for the users.

14. INSTRUCTION FOR USE

14.1 Preliminary procedure assessment

1. Administer anticoagulants and monitor Activated Clotting Time per standard Site's guidelines. Anticoagulant treatment should be monitored to grant an adequate Activated Clotting Time for the entire duration of the procedure (at least 250 s);
2. Confirm the ilio/femoral arteries conformation and dimension comply with indication and contraindication for use;
3. Confirm the aortic arch location where the filter will be deployed and the relative dimensions by injection of contrast media under fluoroscopic examination;
4. Confirm the device size as per aorta diameter and aortic arch dimensions as specified by the sizing table (Table 3);

14.2 Device compatibility

FLOWer's device compatibility with working catheters with different stiffness and dimensions has been assessed in preclinical operative conditions. The compatibility assessment has been performed also in clinical operative conditions in case of TAVI, testing the main TAVI delivery systems available on the market. FLOWER has never demonstrated incompatibility with delivery systems with a dimension lower than 18 Fr (if used with customized pigtail) or 21 Fr (if used without customized pigtail).

WARNINGS:

- Use carefully in case of device with shaft diameter exceeding 18 Fr crossing the filter.
- Small, reduced-calibre working catheters (including guidewires) may roll-up inside the FLOWER device. In this case, align the guidewire tip with the guide catheter tip; once aligned, navigate both concurrently through the filter to overcome the device. FLOWER device can interfere with particularly stiff working device during their navigation. If interaction occurs, carefully advance and slightly turn the working catheter. If it is not possible to cross the filter, extract any working catheter from the FLOWER device, retrieve FLOWER and reposition it upstream or downstream according to the anatomy and try again to cross the filter with the device. If unsuccessful, retrieve the FLOWER device and perform the main procedure without protection.
- Verify compatibility with TAVI delivery systems whose eventual recapturing is performed in descending aorta.

14.3 Required Accessories

FLOWer procedure needs the following accessories:

Material needed for device priming:

- 1 l of sterile heparinized saline solution (5000 UI/l of heparin);
- 1 x Luer syringe 10 ml;
- 1 x 0.035" diameter floppy tip guidewire, non-hydrophilic coated 260 cm.

Material needed for procedure:

- Femoral artery introducer compatible with a 12 Fr device catheter;
Note: it is preferable to use a long introducer in case of anatomical tortuosity.
- 0.035" diameter floppy tip, super stiff guidewire, 260 cm minimum length, non-hydrophilic coated.
Note: it is preferable to use a pre-curved guidewire for FLOWER navigation to prevent accidental cardiovascular damages.

14.4 Packaging handling

1. Open the carton box from the long side and take the device pouch;
2. Open the device pouch by peeling the two extremities of the welding;
3. Extract the blister containing FLOWER and its accessories from the pouch and put it on a sterile table.

WARNING: the content of the SBS is sterile: only sterile operator can touch the content of the SBS

FLOWer Instructions for Use

14.5 Device Priming

1. Keeping the device inside its blister, remove the two transport clips (2) from the tray (1) and unlock the strips (4);
2. Remove the stylet (R) from the guidewire port (D) and insert it distally in the device, from the tip (L);
3. Fill the tray (1) with sterile heparinized saline solution, submerging the filter (G);
4. Remove the priming clip (3) from its housing and put it over the proximal extremity of the tray in order to keep the filter (G) submerged;
5. Gently advance the pigtail (Q) until all the holes on the soft tip (Q1) are out of the catheter (K) and flush its lumen(Q) with sterile heparinized saline solution until all air is removed (no bubbles shall be present);

WARNING: If some resistance is perceived, slightly retract a bit the pigtail (Q) and advance it again

6. Flush through the pigtail-dedicated lumen flush port (E1) sterile heparinized saline solution until all air is removed. To facilitate the flushing towards the soft tip of the outer catheter (K), advance the pigtail straightener (S) until its tip touches the pigtail port (E), without engaging it.
7. Flush through the outer catheter flush port (C) sterile heparinized saline solution until all air is removed;
8. Load the guidewire 260 cm long inserting its soft tip inside the pigtail lumen (Q) from the pigtail port and making it protrude from the distal extremity of the pigtail (Q) enough to straighten the pigtail tip (Q1);
9. Retrieve the pigtail (Q) till its distal extremity enters the outer catheter (K)
10. Position the pigtail guidewire inside the filter (G) by advancing it through the proximal structure port (H) until it reaches the proximal structure distal ring (H1);
11. Flush through the outer catheter flush port (C) sterile heparinized saline solution until all air is removed;
12. Gently remove the bubbles from the filter surface smoothly moving it;
13. Unlock the safety ring of the distal structure slider (M) by rotating it;
14. Move back distal structure slider (A) until it blocks in the preclosing position (A2);
15. Move forward the outer catheter slider (B) until it blocks in the preclosing position (B2);
16. Flush through the outer catheter flush port (C) sterile heparinized saline solution until all air is removed;
17. Unlock the distal structure safety lever (N) and move back the distal structure slider (A) in the closed position (A3) until the distal structure slider reaches the handle limit switch;
18. Lock the safety ring of the distal structure slider (M) by rotating it;
19. Unlock the outer catheter safety lever (O) and move forward the outer catheter slider (B) in the closed position (B3) by squeezing the relative fin, until the catheter reaches the device tip (L);
20. Remove the device stylet (R);
21. Flush through the guidewire port (D) sterile heparinized saline solution until all air is removed.

WARNINGS:

- Be sure that heparinized saline solution is sterile and that it has not been contaminated after opening.
- Do not use a device that has not been properly flushed and de-aired. Failure to prepare and flush the device before use may introduce air and result in serious patient injury.

14.6 Procedural use – Deployment

WARNINGS:

- Do not use the device if it has been contaminated by users' blood and/or particles during the removal from the packaging or the flushing.
- Handle the device following operating room common practice. Do not leave the device in contact with non-sterile surfaces before and during the procedure.
- Before inserting the device, verify that sliders are locked in position.

1. Using standard interventional technique, place a 12 Fr introducer into the patient femoral artery opposite to the working device access.

WARNING: sew the introducer on the femoral artery to avoid displacement of the introducer during the procedure.

2. Insert a proper super stiff floppy tip 0,035" guidewire into the introducer until it reaches a stable position inside the ascending aorta.

FLOWer Instructions for Use

- Backload the guidewire in the device tip (L) and slide it inside the device until it exits from the guidewire port (D)

WARNINGS:

- During the insertion, be sure that the guidewire soft end is not inside the device, but it must come out of the device tip.
- Advancing the device firmly hold the guidewire that exits from the device handle.
- Do not advance the device guidewire in the ventricle.

- Insert the device in the introducer holding the device so that the outer catheter flush port (C) is facing up.
- Advance the device in ascending aorta, until the epiaortic vessels are protected.

Note: the bottom of the radiopaque tip (L) should be placed at least 10 mm upstream the insurgence of the innominate artery.

WARNINGS:

- During the device navigation along the vessels take care not to abruptly push the device, forcing the navigation. In case any resistance is perceived crossing the aortic arch, in order to avoid damages to the aortic wall, stop the advancement, gently retract few millimetres the FLOWer device with a small rotation and push forward again. Use the radiopaque tip (L) and the radiopaque ring placed on the outer catheter (K) of the FLOWer device to localize its position.
- Do not push the device tip too close to the aortic valve to avoid aorta perforation or coronary ostia dissections.

- Using the radiopaque tip (L) as marker reference confirm the final position of the device before starting the filter deployment.
- Holding firmly the device handle (P), move back the outer catheter (K) acting on the outer catheter slider (B) until reaching the open position (B1) by squeezing the relative fin.
- Deploy the device distal structure (F) by moving forward the distal structure slider (A) and continue to move forward the slider until the adequate apposition to the aortic wall is reached (between A1 and A2).

WARNINGS:

- If resistance is perceived when starting the distal structure expansion, fully collapse it, advance the outer catheter (K) until it reaches the tip by fully advancing the outer catheter slider (B), retract the FLOWer, and then advance it again. Attempt positioning once more; if the issue persists, replace the device.
- During the deployment pay attention that the distal structure (F) opens correctly as in Figure 8A. If it opens incorrectly (as for example in Figure 8 B and C), the operator should retrieve the device inside its catheter as described in “13.5 Device Priming” chapter points from 17 to 22. Then, the operator should extract the device from the introducer, rotate the catheter 90° (eg. Figure 8B) or 180° (e.g., Figure 8C) and reinsert it from the introducer. Then, a new deployment procedure as described in points from 7 to 9 of this chapter can be attempted.
- Do NOT rotate the device when the distal structure (F) is fully deployed in the open position.
- A maximum of three positioning procedures are allowed.

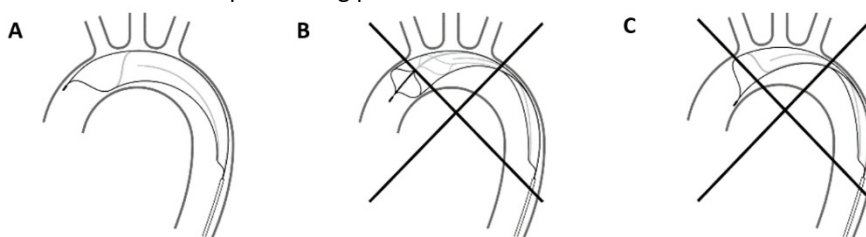

Figure 8 - FLOWer device correct positioning (A-left); device incorrect positioning (B-center, C-right)

- When the distal structure (F) is adequately positioned on the aortic arch, lock the safety ring of the distal structure slider (M) by rotating it.
Note: it is possible to check the correct positioning of the device verifying the wall apposition by means of fluoroscopy and controlling the epiaortic vessels perfusion.
- (If the pigtail is not used please jump to 13) Advance the pigtail (Q), cross the distal structure (F), and position it where it is convenient to have a good visualisation of the anatomical structures interested for the main procedure .
Note: if necessary, the pigtail straightener (S) can be inserted in the pigtail port (E) to promote the pigtail sliding. Once the pigtail is properly positioned, remove the pigtail straightener (S) from the port.
- Remove the guidewire from the pigtail (Q);

FLOWer Instructions for Use

12. Connect the pigtail (Q) to the contrast media injector to confirm the device correct position using fluoroscopy: the distal structure (F) shall offer a good apposition to the aortic wall.

Note: it is recommended to set at least 1000 psi in the contrast media injector machine to ensure a good visualization.

WARNINGS: ensure that the pigtail (Q) is well connected to injector machine to avoid return blood.

13. Place the device handle in a safe position on the surgical table to avoid sudden mis-positioning of the distal structure (F).

14.7 Procedural use – Interaction with other devices

This chapter applies to procedures that require the passage of the working catheter through the FLOWer device. If FLOWer crossing is not required, perform the main intervention as per standard procedure.

1. Advance the other devices guidewire through the FLOWer device proximal structure port (H) using a guide catheter (e.g., Judkins Right) and overcome the proximal ring of the distal structure (F1).

Note: to favour the FLOWer crossing, it is suggested to advance the working catheter and its guidewire concurrently, maintaining the guidewire completely inside the working catheter to stiffen the distal part. It is preferable to use a guidewire with a major load soft tip and a working catheter with a stiffer tip and/or with a tip shape that helps to direct the device towards the filter port. Rotate the guide catheter facilitating the access in the filter port according to its tip shape.

Note: to avoid the twist of the guide catheter/guidewire around the FLOWer outer catheter, it is preferable to use a guidewire with a short floppy tip and to follow its advancement through the fluoroscopy machine. Once the guidewire is inside the filter, check that it can move and detach from the spine of the FLOWer in abdominal aorta.

Note: during the navigation of the guide catheter/guidewire, movements of the proximal structure toward the small aortic curvature (intradors) give indication on its correct crossing of the filter. If the working device interacts at level of proximal ring of distal structure, it is possible that the device is passed out from the filter and be stuck between the filter and the aortic wall. In this case, retract the working catheter up to the FLOWer outer catheter and then advance it again. In any moment the user can change the angiographic projection to verify the correct crossing of working catheters.

2. If necessary, replace the guide catheter/guidewire with the device required by the procedure, in according to section § 14.2 - Device compatibility

WARNINGS:

- If the working catheter or other device can't across the filter, gently move its guidewire to support the crossing. Perform this action in gentle way because an excessive force on the guidewire could cause an aorta's wall dissection or even worse a vessel perforation.
- In case of TAVI recapturing and repositioning, the recapturing must not be done in descending aorta with the FLOWer device in the open position.
- If valvuloplasty is performed during procedure, check that the balloon is completely deflated before its retrieve to avoid any interaction with the device.

3. In any moment it is possible to re-position the pigtail (Q) in another aortic valve sinus.

14.8 Procedural use – Retrieval

1. If applicable, disconnect the pigtail (Q) from the contrast liquid injector and withdraw it inside the outer catheter (K).
2. Be sure that the guidewire is loaded inside the device. If possible, make sure that the soft part at the extremity of the guidewire is completely out from the tip (L) of device before the retrieval.
3. Unlock the safety ring of the distal structure slider (M) by rotating it.

WARNING: check every working catheter together with its guidewire is removed from the filter before retrieving it.

4. Close the filter (G) collapsing the device distal structure (F) by moving back the distal structure slider (A) pushing the relative fin, until it stops in the preclosing position (A2).
5. Push forward the outer catheter slider (B) pushing the relative fin, until it stops in the preclosing position (B2).
6. Unlock the distal structure safety lever (N) and move completely back the distal structure slider (A) in the closed position (A3) by pushing the relative fin.
7. Lock the safety ring of distal structure slider by rotating it (M).

FLOWer Instructions for Use

8. Move the device in the descending aorta by moving the handle (P).

WARNING: Perform the retrieve of the device in descending aorta, paying attention not to do it close to the femoral bifurcation. If the device is too close to the bifurcation, the distal tip of the standard-length introducer may interfere with the retrieve procedure.

9. Unlock the outer catheter safety lever (O) and capture the device moving forward the outer catheter slider (B) to the closed position (B3) by squeezing the relative fin, until the catheter reaches the device tip.
10. Withdraw the device from the introducer.
11. Using standard interventional techniques, remove the introducer and close the femoral artery access.

WARNING: Check that the device is fully closed. The radiopaque tip should be in continuity with the radiopaque ring present on the distal portion of the outer catheter (K). In case the closure is incomplete repeat the closure procedure retracting and re-advancing the outer catheter (K) until full closure is obtained.

15. COMPLAINTS AND MALFUNCTIONING

In the event of a product complaint or malfunction the Healthcare Professionals, patients or users shall immediately advise the Distribution Organisation. The Distribution organisation will take care of the device segregation and return.

16. DEVICE DISPOSAL

Once the device has been withdrawn from the patient, it must be disposed except if it has shown malfunctions.

Dispose of product and its packaging in accordance with hospital, administrative, and/or local government policy:

- The device and accessories are biologically hazardous due to the contact with patient's blood;
- The tray and the clips are made of PETG;
- The card is made of HDPE;
- The pouch is made of Tyvek and BOPET / PE;
- The external box is made of carton;
- The stylet is made of AISI;
- The case back is made of ABS plastic.

WARNING: since the device and accessories during their use is in contact with blood and other biological tissues, an incorrect disposal of the device can lead to contamination of people or environment.

17. WARRANTY

Although the product has been manufactured under careful controlled conditions, AorticLab srl has no control over the conditions under which the product is used by the customer or by any third party. Therefore, AorticLab srl expressly disclaims any and all warranties, both expressed and implied, with respect to product including, but not limited to, any implied warranty of merchantability, infringement or fitness for a particular purpose.







In no event AorticLab srl shall be liable to the customer and/or to any third party for any indirect damages including but not limited to consequential, special or incidental damages whatsoever arising from, caused and/or in any way related to any use, defect, failure or malfunction of the product, whether a claim for such damages is based upon warranty, contract, tort or otherwise. The exclusions and limitations set out above, are not intended to, and should not be construed so as, to contravene any mandatory provisions of applicable laws.

18. MANUFACTURED BY

AorticLab srl
Via Ribes 5,
10010 Colletterto Giacosa (TO) Italy
0039 011 18838598
<https://www.aorticlab.ch/>

19. FLOWer HANDLE SYMBOLS

The handle of the device is engraved with the following symbols that help the user to perform the correct displacements of sliders during the deployment and the retrieval of the device once it has been placed inside the aortic arch.

	<p>It indicates the position of the outer catheter slider in which the outer catheter is closed.</p>
	<p>It indicates the position of the outer catheter slider in which the outer catheter is open.</p>
	<p>It indicates the position of the distal structure slider in which the distal structure is open. (Note – the dimension of the symbol is relevant for the meaning, referring to the following symbol)</p>
	<p>It indicates the position of the distal structure slider in which the distal structure is closed. (Note – the dimension of the symbol is relevant for the meaning, referring to the previous symbol)</p>
<p>RESET </p>	<p>It indicates the direction in which to move the Outer catheter safety lever (O) and Distal structure safety lever (N) to unlock the mechanism.</p>
	<p>It indicates where to stop when sliding backward the distal structure slider.</p>

20. FLOWER LABELS SYMBOLS



Manufacturer



Do not re-use



Date and country of manufacture



Do not use if package is damaged

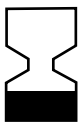

Use by date



Do not re-sterilize



Catalogue number



Sterilized using ethylene oxide

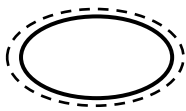

Single sterile barrier system with protective packaging outside



Single sterile barrier system

www.aorticlab.ch



Consult electronic instructions for use

INTRODUCER SHEATH ≥ 12 Fr

Recommended introducer



Non-pyrogenic

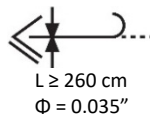

Recommended guidewire



CE Mark



Keep dry

FLOWer Instructions for Use



Fragile: handle with care



Keep away from sunlight



Medical device



Unique Device Identification



Patient information website



Lot

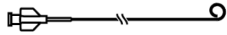

Pigtail



Maximum stacking number

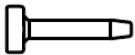

Pigtail Straightener



Stylet

21. TROUBLESHOOTING GUIDE

Physicians' maneuvers on the FLOWer device in case of procedural problems.

	Type of Event	Recommended corrective action
1	The navigation of the device in the femoral artery results difficult	<ol style="list-style-type: none"> 1. Check again the CT scan measurements and confirm that the femoral artery has a suitable diameter for a 12 Fr device. 2. Check the guidewire in use is a super stiff type.
2	The device causes peripheral arteries or aortic dissection during the advancement into the arterial vessels	Retrieve the FLOWer device and proceed with endovascular/cardiovascular most appropriate treatment under the Physician's judgement.
3	The device navigates difficultly in the aortic bifurcations	<ol style="list-style-type: none"> 1. Move the device backward and forward to ease the navigation. 2. Use a long introducer to straight the vessel and ease the navigation
4	The device does not reach the intended positioning in the aorta's extradors	Move forward the guidewire reducing the wire/catheter traction.
5	The device landing zone is on a dangerous area (plaque)	Try to find a safer landing zone upstream or downstream always providing that the epiaortic vessels are covered. If the risk remains high, under the Physician's judgement, don't deploy the FLOWer device and retrieve it.
6	The outer catheter does not slide back / remains blocked during the deployment procedure	Retry the opening procedure. If the FLOWer device can't be fully deployed, close and retrieve it out of the patient and use another FLOWer device.
7	The outer catheter does not slide forward during the filter retrieval procedure	<ol style="list-style-type: none"> 1. Do not exercise excessive pressure on the outer catheter's slider. Check if any working catheter/guidewire is still inside the filter. If yes, remove all of them and re-try the retrieval procedure. 2. If a partial closure can be achieved, retract the FLOWer device all in one with its introducer. 3. If this procedure is unsuccessful proceed with a surgery.
8	The distal structures do not deploy completely	<ol style="list-style-type: none"> 1. Do not exercise excessive pressure on the distal structure slider. Verify if in the landing zone circular calcifications are present. If so, try to find a safer landing zone always providing the epiaortic vessels are protected. 2. Otherwise, collapse the distal structure using the slider, close the FLOWer device advancing the outer catheter, retrieve the device and advance it again. Attempt a new device deployment (Note: always avoid abrupt slider's movement during the distal structure deployment). 3. If unsuccessful, close the FLOWer device advancing the outer catheter as much as possible, retrieve it out of the patient and use another FLOWer device.
9	The distal structures do not completely fit to the ascending aorta	<ol style="list-style-type: none"> 1. Check on the handle if the outer catheter's slider is completely backward and if the distal structure's slider reached its end run forward. 2. If still does not completely appose please check again the aortic measurements and confirm the choice of FLOWer model is correct: <ol style="list-style-type: none"> a. If yes re-deploy the device upstream to get good apposition.

FLOWer Instructions for Use

	Type of Event	Recommended corrective action
		b. If no close the FLOWer device, retrieve it and use another FLOWer device with a bigger size.
10	The distal structures are rotated respect to the expected positioning	Check that the outer catheter flushing port is facing up 1. If no, retrieve the device out of the introducer and re-insert it properly aligned. 2. If yes, a repositioning is needed. Close the FLOWer distal structure by actioning the appropriate slider on the handle; release the guidewire tension and retract the device in descending aorta; carefully and slowly rotate the FLOWer device of 90° or 180° according to Figure 6. If the procedure is unsuccessful close the FLOWer device, retrieve it and use another FLOWer device.
11	The device nitinol structures are not in the expected position (too upstream/too downstream)	Collapse the FLOWer distal structures actioning the appropriate slider on the handle; move the FLOWer device in the adequate position than re-deploy the FLOWer distal structures.
12	The device distal structures dissect the aortic wall or plaque	If it is safely possible, complete the procedure, then close and retrieve the FLOWer device. The Physician must evaluate how to proceed with the appropriate endovascular/surgical treatment.
13	The working device does not center the proximal filter structure	Retract the working device and using the standard intervention technique move it forward until it enters inside the filter structure. Check if a possible guidewire kinking occurs. <i>Note: It is always recommended using a Judkins right angiographic catheter to center the proximal structure and crossing the entire filter then advance the guidewire.</i>
14	The working device guidewire remains stuck inside the device	1. If the guidewire is rolled-up inside the filter, retract it until it enters inside its working catheter (after ensuring that it is inside the filter) and advance them together. 2. Check if the guidewire is passed between the distal structure and the filter fabric. If so, collapse the distal structure a bit, pull back the working catheter a bit without exiting from the filter, re-expand the distal structure ensuring that it is completely adherent to the aortic wall and advance again the working catheter.
15	The working catheter cannot advance inside the filter because its guidewire is twisted around the outer catheter	Pull back the working catheter until the femoral bifurcation and gently slightly pull the FLOWer handle in order to straighten the outer catheter. Then, advance the working catheter without twisting it, following its navigation by fluoroscopy machine.
16	The working catheter does not progress and remains stuck inside the device	1. In case of flexible and small catheter, to solve the interaction advance the guidewire first and then move the working catheter over it. 2. In case of stiff and large device, move it back, if possible, slightly rotate the working device and try again. If the working device does not progress, retrieve a little back its delivery in descending aorta out of the filter. Fully collapse the FLOWer distal structure with its relative slider, reposition it upstream or downstream according to the anatomy and try again to cross the filter with the working device. If unsuccessful, remove the device with its guidewire from the filter, retrieve the FLOWer device and complete the procedure without protection.

FLOWer Instructions for Use

	Type of Event	Recommended corrective action
17	The working device remains stuck inside the device after the procedure	<p>Move forward the working device and using the standard intervention technique slightly rotate the delivery and try again. If applicable, try to close the delivery system and try again to retract it. If the working device does not retract:</p> <ol style="list-style-type: none"> 1. Push the working catheter guidewire to release the tension on it and to push the delivery system toward the extrados. 2. Otherwise, partially close the FLOWer distal structures and move the ensemble (FLOWer plus working catheter) into the descending aorta. Re-deploy the FLOWer distal structures in its intended position and try again to retrieve back the delivery system also aiding with small rotations. 3. In case also this procedure is resulting unsuccessful the Physician should consider a surgical procedure to recover the ensemble (FLOWer device plus working device).
18	The valvuloplasty balloon remains stuck inside the filter during its retrieval	<ol style="list-style-type: none"> 1. Advance a bit the balloon, inflate it partially and deflate it completely. Then, try to retrieve it again pushing the guidewire toward the extrados. 2. If unsuccessful, repeat point 1 leaving some contrast media inside the balloon during the deflation.
19	The device distal structures cannot be closed	<ol style="list-style-type: none"> 1. Check the locked mechanisms are unlocked; 2. If a partial closure of the distal structures can be achieved, retract the FLOWer device all-in-one with its introducer; 3. Retry and, if unsuccessful, then proceed with a surgery.
20	The device distal structures do not respond to the related slider during retrieval, remaining expanded when it is pulled back.	<p>To collapse the distal structure is necessary to expose the two NiTi wires from handle. To do it:</p> <ol style="list-style-type: none"> 1. Remove the distal structure slider from the body of the handle, opening its components. 2. Lift the upper shell of the handle. 3. Pull back the two thinner NiTi wires placed under the green plastic component until the distal structure is collapsed.
21	The tip of the device detaches from the filter structure (possible embolization)	<p>Close and retrieve the FLOWer device out of the patient. The Physician should submit the patient to a fluoroscopic examination of peripheral vessels in order to identify, localize and remove the radiopaque embolized component.</p>
22	The fabric filter partially detaches from the nitinol structure	<p>Try to close and retrieve the FLOWer device.</p> <ol style="list-style-type: none"> 1. If the device cannot pass through the introducer try to remove all-in-one the device and the introducer 2. In alternative prepare the access site to remove the device with a vascular surgery intervention. The Physician will evaluate the best option.
23	The device proximal structure partially detaches from the catheter (no embolization)	<p>Try to close and retrieve the FLOWer device.</p> <ol style="list-style-type: none"> 1. If the device cannot pass through the introducer try to remove all-in-one the device and the introducer. 2. In alternative prepare the access site to remove the device with a vascular surgery intervention. The Physician will evaluate the best option.

FLOWer Instructions for Use

FREE FOR NOTE

FLOWer Instructions for Use

 0123



AorticLab S.r.l.
Via Ribes 5, 10010 Colletterto Giacosa
(TO) Italy

The SSCP is available in the European database on medical devices (EUDAMED), where it is linked to the Basic UDI-DI.

URL to EUDAMED public website:

<https://ec.europa.eu/tools/eudamed>

Basic UDI-DI:

805750010FLOWER9S